



Garden Watering Systems

Model Numbers:

SJ35-04, SJ35-04PC, SJ60-08PC

SJ35-04

This is a manual pump, suitable for connection to a standard power outlet and switched on and off as required.

SJ35-04PC & SJ60-08PC

These are automatic models, suitable for connection permanently to a power supply and will start and stop according to flow demands.

APPLICATIONS

- Garden watering
- Garden hoses
- Dripper systems
- Garden sprinklers

WHY CHOOSE OUR GARDEN WATERING SYSTEMS?

Your rainwater tank captures and saves water. To use it effectively around the garden Davey has developed the garden range of pumps to economically satisfy these needs.

Davey are known worldwide for the quality and reliability of their pumps, and the garden range has been developed to live up to this enviable reputation.

While the domestic backyard may not be as harsh as the Australian outback, Davey know that reliability is just as important to you. Davey garden watering pumps are manufactured to the exacting standards Davey have established for all their products.

Important components like bearings, capacitors, seals, controls and tanks have all been specified to Davey's standards. The range of garden watering pumps will provide a dependable, value for money investment.

Pump

Single stage jet assisted centrifugal pump:

- Higher operating pressures.
- Less moving parts for increased dependability.
- Self priming for easier installation.

Corrosion resistant and stainless steel pump components:

- Longer life when pumping a variety of water qualities.
- Reduced friction within the casing and impellers.

High quality purpose built 2 pole, 50Hz, IP55 TEFC pump motors, designed to Davey's high quality specifications with:

- Permanent split capacitor starting for dependable and frequent starting everytime.
- In-built thermal overload for long motor life and protection against motor damage due to jamming.
- High quality sealed bearings for longer life.
- Fitted with a power lead and three pin plug for ease of connection to power supply.
- Resists ingress of dust & dirt.

Hydraulic assembly attached to motor bracket at 8 points with oring seal to the stainless steel pump casing:

- Better sealing.
- Longer service life.

Designed with the serviceman and installer in mind:

- Suction and discharge are close for easier installation.
- Quality components throughout for long life and easier maintenance.

Every pump is performance and pressure tested in the factory to ensure quality and reliability.

Press Control

In-built check valve for easier installation.

In-built spring & diaphragm shock absorber:

- No need for pressure tanks on many installations.

No adjustments for operation:

- Constant non-cycling pump operation.

Solid state electronic control circuit with "tropicalization" treatment:

- Longer life.

Loss of prime protection:

- Saves pump from damage when water supplies run out.



OPERATING LIMITS	
Flow capacities to	80 lpm
Pressure heads up to	42m
Maximum operating pressure	600 kPa
Maximum incoming (suction) pressure	140 kPa
Maximum ambient temperature	50°C
Maximum water temperature	45°C
Minimum water temperature	1°C
Single phase (supplied with 3 pin plug)	1 x 230V ± 10%
Frequency	50Hz
Protection (motor)	IP55
Suitable fluids	Clean potable water of neutral ph containing no solids or abrasives.

ELECTRICAL DATA		
Model	SJ35-04	SJ60-08
Nominal rpm	2900	
Volts / hertz / phase	220-240 / 50 / 1	
IP rating / insulation	55 / Class F	
Amps	2.35	4.8
kW (P ₁) / (P ₂)	0.53 / 0.37	1.16 / 0.9
Capacitor	13 _μ F	20 _μ F

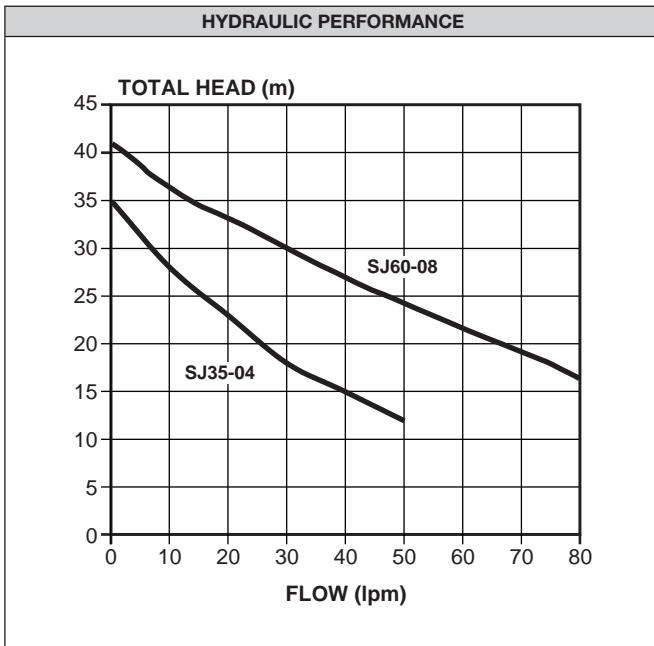

MATERIALS OF CONSTRUCTION	
Part	Material
Pump	
Impellers	304 stainless steel
Pump casing	304 stainless steel
Pump shaft	304 stainless steel
Seal ring (stationary): SJ35-04	Ceramic
Seal ring (stationary): SJ60-08	Silicon Carbide
Seal ring (rotating)	Carbon
Seal ring elastomer	EPDM
Seal spring: SJ35-04	304 stainless steel
Seal spring: SJ60-08	316 stainless steel
Orings	EPDM
Jet / venturi / coverplate	Glass filled thermoplastic
Motor shell	Aluminium
Shell finish	Polyester
Press Control	
Housing	Glass fibre reinforced polyamide PA 6 GF 30%
Diaphragm	EPDM
Spring	Steel C 72 UNI 3545
Flow valve	Brass OT 58 UNI 5705 / 65
Check valve	Glass fibre reinforced polyamide PA 6 GF 30%
Control box	Self extinguishing thermoplastic resin VO
Printed circuit	Vetronite

GARDEN WATERING FLOW RATE GUIDE	
<p>The SJ35-04 pump models can supply a variety of garden watering applications, such as :-</p> <ul style="list-style-type: none"> • A garden hose with a spray nozzle fitted, or; • A garden spray system with up to 25 microjet sprays, or; • A garden dripper system with up to 200 garden drippers (4 litre per hour drippers), or; • Two small impact sprinklers 	
<p>The larger SJ60-08PC model is capable of up to double the above, though still suitable for running a single garden hose.</p>	
<p>With the correct selection of pipework, valves and automatic irrigation controller, the range of models can even be used to power a fully automated watering system.</p>	
<p>Your garden watering professional can give you the best advice on how to utilise the valuable rainwater you have captured for the most efficient usage in your garden.</p>	

DIMENSIONS

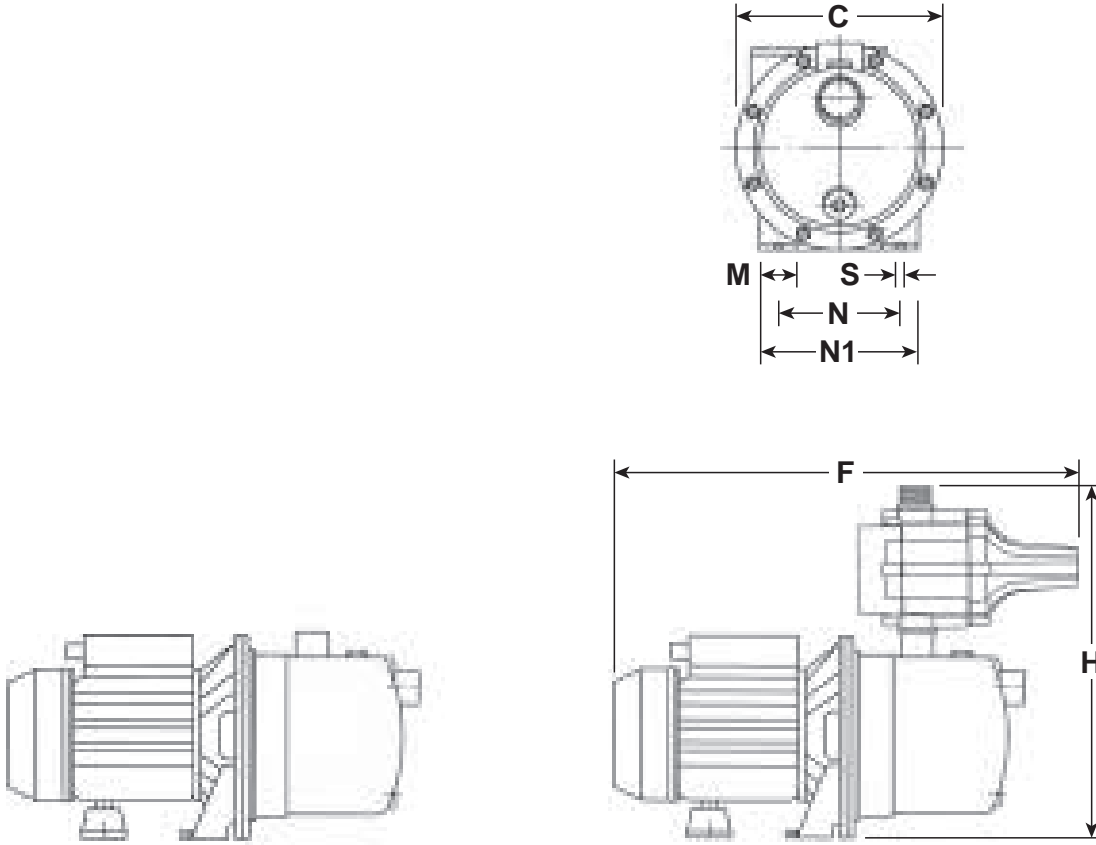

Model	A	B	C	F	H	H1	H2	M	N	N1	S	W	Inlet B.S.P.	Outlet B.S.P.	Net Weight (kg)
SJ35-04	90	82	170	355	174	128	N/A	30	100	130	7	107	1" F	1" F	5.6
SJ35-04PC	90	82	170	355	323	128	N/A	30	100	130	7	107	1" F	1" F	7.0
SJ60-08PC	100.5	82	213	415	472	158	N/A	39	120	158	7	142	1 1/4" F	1" F	11.9

All dimensions in mm unless otherwise stated.

DAVEY davey.com.au | daveynz.co.nz

This literature is not a complete guide to product usage. Further information is available from your Davey dealer, Davey Support Centre and from the relevant product Installation and Operating Instructions. This data sheet must be read in conjunction with the relevant product Installation and Operating Instructions and all applicable statutory requirements. Product specifications may change without notice.
 © Davey and Steriflo are registered trademarks of Davey Water Products Pty Ltd. © Davey Water Products Pty Ltd 2013.

